

(No Model.)

H. REMILLARD.

MACHINE FOR RECUTTING CARRIAGE AXLES.

No. 251,286.

Patented Dec. 20, 1881.

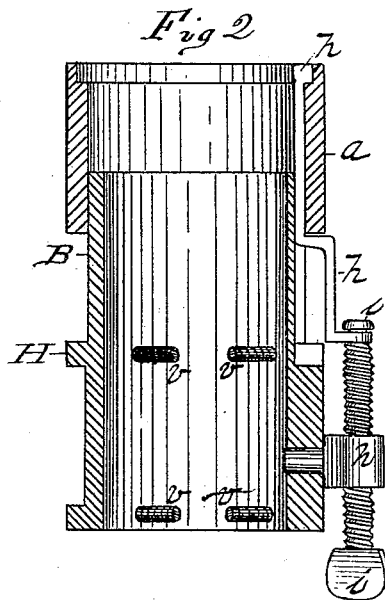
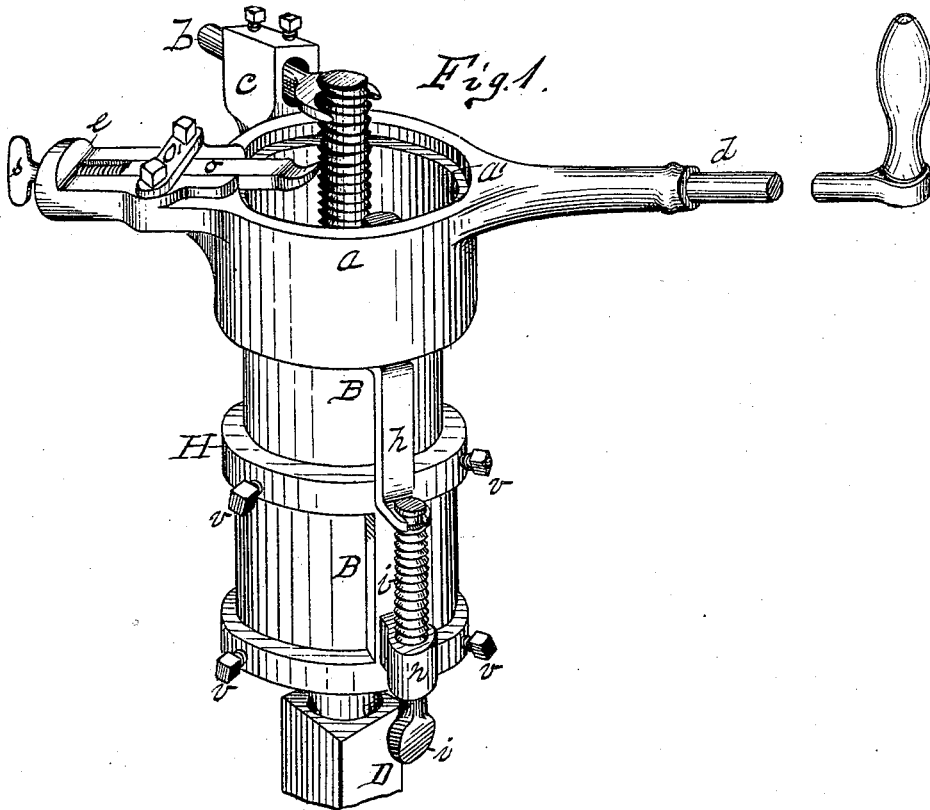

Witnesses
J. B. Fairfield
C. J. Brown

Inventor
Homer Remillard
By Henry A. Chapin
Att'y

UNITED STATES PATENT OFFICE.

HOMER REMILLARD, OF NORTHAMPTON, MASSACHUSETTS.

MACHINE FOR RECUTTING CARRIAGE-AXLES.

SPECIFICATION forming part of Letters Patent No. 251,286, dated December 20, 1881.

Application filed July 18, 1881. (No model.)

To all whom it may concern:

Be it known that I, HOMER REMILLARD, a citizen of the Dominion of Canada, residing at Northampton, in the county of Hampshire and State of Massachusetts, have invented new and useful Improvements in Axle Turning and Threading Machines, of which the following is a specification.

This invention relates to the construction of a portable axle turning and threading machine, the object being to provide a light and convenient machine for the use of wagon-makers and blacksmiths and other artisans, for re-turning axles and for recutting and extending the screw-thread thereon, and for doing similar work upon other articles made from metal, which can be held in a vise and operated upon, and to provide a portable tool which for many purposes is a convenient and useful substitute for the ordinary metal-turning lathe.

In the drawings forming part of this specification, Figure 1 is a perspective view of my improved axle turning and threading machine. Fig. 2 is a view of a portion of the cylinders of the machine in vertical section, and showing detail parts in full lines.

In the drawings, B represents a metallic cylinder, provided with a series of set-screws, *v*, through its sides, all pointing toward the center thereof. Said cylinder B is perforated to receive the shank of a nut, *n*, in which operates a thumb-screw, *i*. The shank of nut *n* fits sufficiently close in said perforation in cylinder B for all operative purposes; but it and screw *i* may be removed and replaced at will, as and for the purpose hereinafter stated. That portion of cylinder B above the ring H is turned smooth, and thereupon is fitted the cylindrical tool-carrier *a*. A hook, *h*, has its upper portion let into a groove formed in said smoothly-turned part of cylinder B, and the upper end of said hook hooks over a shoulder, *a'*, around the inner edge of the tool-carrier *a*, and the lower part of said hook bends outwardly beyond the edge of ring H on cylinder B, and has a cut in its lower end to adapt it to hook into a groove cut around screw *i*, near its upper end. The above-described screw *i* and hook *h* may be properly designated as the "feed-screw" and "hook."

The tool-carrier *a* is adapted to be revolved upon one end of cylinder B by the crank *d*,

and is provided with two rests, *e* and *e*, in which the tool *o* and screw-thread follower *b* are respectively secured, pointing toward the center of said tool-carrier, as shown in Fig. 1.

In the tool-rest *e*, is secured, by the strap *o'* and screws through it, the tool *o*, which may be like any metal-turning, cutting-off, or thread-cutting tool such as is ordinarily used in turning-lathes, and said tool *o* is fed against the work by the screw *s* through the outer end of rest *e*.

The rest *e* is adapted to hold the screw-thread follower *b*, having one end cut out, of half-round form, to partially encircle the threaded end of an axle-skein, and having its edge adapted to enter between the screw-threads of said axle-skein. The shank part of the thread-follower *b* is held in the rest *e* by two screws, as shown, and the hole through said rest is made larger than the shank of said follower *b*, to provide for such adjustments of the follower to its work as may be required.

In Fig. 1 is shown the end of an axle, D, in position within the axle turning and threading machine, the latter being secured thereon by the screws *v*.

In repairing vehicles it frequently becomes necessary, on account of the end or other wear of the wheel-hub, to cut the thread on the end of the axle-skein farther up on the skein, and to cut off the end of the latter. The tools usually provided in a wagon-maker's or blacksmith's shop do not afford conveniences for doing thus work, and hence the axle must generally be carried where the use of a lathe can be had; but by providing one of my machines, as herein described, said work may be easily and expeditiously done where the usual repairing is, and its operation therefor is as follows:

When the screw-thread on an axle-skein is to be cut farther back from the end thereof, cylinder B is secured by screws *v* on the skein in the position shown in Fig. 1, and by said screws is so adjusted as to bring said skein central therein. Previous to extending said thread the axle-skein, at the point thereon where said thread terminates, must be turned down, as usual, to the proper diameter, and to arrange the machine to do this the thread-follower *b* is loosened in the rest *e* and drawn back so as not to engage in the thread on the axle-skein,

and a proper turning-tool is secured in the tool-rest *e*. It will now be seen that the tool-carrier *a* may be freely revolved upon cylinder B, but that it cannot slide longitudinally there-
 5 upon, except as moved by turning screw *i*. Therefore screw *i* is turned to slide the tool-carrier *a* on said cylinder until the point of the tool *o* is brought where it is desired to commence turning down said skein, when screw *s*
 10 is operated to feed the tool *o* forward. The carrier *a* is revolved by crank *d*, and by turning screw *i* the carrier *a* and tool *o* are caused to be moved over the skein in a direction toward or from its end, thus producing the same re-
 15 sult as to the reduction of the diameter of the skein as though the latter were operated upon in a lathe.

The cutting off of the end of the skein is accomplished by leaving the machine in the
 20 above-described condition, but using a proper cutting-off tool, and feeding it against the skein by screw *s*, while screw *i* is permitted to rest undisturbed. After the skein shall have been turned to the proper diameter for the exten-
 25 sion of the thread, as above described, the machine is adjusted for cutting the new thread as follows: The nut *n* and the screw *i* are removed from cylinder B, disengaging said screw

from the hook *h*, and the thread-follower is moved forward into engagement with a part of
 30 the old thread on the skein and there secured, the carrier *a* having been first moved on cylinder B, so as to bring the point of tool *o* to the place where the new thread is to commence, when, by turning the crank *d*, the point of tool
 35 *o* will be carried around the skein, and as the follower *b* follows the old thread, so the carrier *a* and tool *o* will be fed along, while said tool is fed forward by screw *s*, and the extended new-cut thread will correspond to the old,
 40 since the latter operates as a feed-screw to carry along the cutting-tool.

What I claim as my invention is—

1. The combination, with the tool-carrier *a*, having crank *d*, and the tool-rest *e* and rest *c*
 45 thereon, of the thread-follower *b*, secured adjustably in said rest *c*, and the cylinder B, substantially as set forth.

2. In combination, the cylinder B, nut *n*, screw *i*, hook *h*, and the tool-carrier *a*, sub-
 50 stantially as set forth.

HOMER REMILLARD.

Witnesses:

H. A. CHAPIN,
 J. D. GARFIELD.